



GN258/GP258

STANDARD COLOR CAMERA



Features

- 1/3 inch Sony Super HAD CCD
- Normal Resolution : 380 TV Lines
- Auto White Balance
- Min Illumination : 0.1 Lux
- AGC, BLC, Flickerless (On/Off)



DIMENSIONS

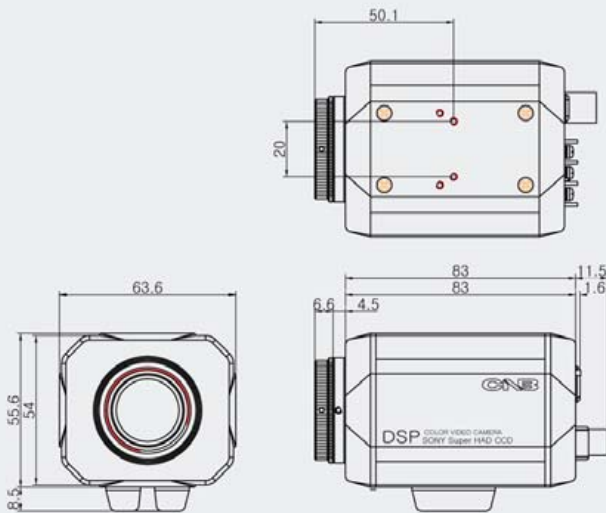

SPECIFICATIONS

Model	-GN258	-GP258
Signal System	NTSC	PAL
Scanning System	2:1 Interlace	
Sync. System	Internal	
Image Sensor	1/3 Inch SONY Super HAD CCD	
Total Pixels	537(H) x 505(V) 270K	537(H) x 597(V) 320K
Effective Pixels	510(H) x 492(V) 250K	500(H) x 582(V) 290K
Horizontal Resolution	380 TV Lines	
Lens Mount	C/CS Mount	
Video Output	Composite: 1.0V p-p, 75Ω, Unbalanced	
S/N Ratio	More than 48dB(AGC Off)	
Min.Illumination	0.1 Lux(F1.4, 30IRE, AGC ON)	
White Balance	Auto	
AGC	On/Off	
BLC	On/Off	
Flickerless	On/Off	
Shutter Speed	1/60~100,000	1/50~1/100,000
Supplied Voltage	DC 12V (10V~15V)	
Power Consumption	Max. 140mA/1.7W	
Dimensions	63.6 x 54 x 94.1 mm	
Weight	335g	