



## -D2815NVD/D2815PVD

100mm DOME CAMERA



### Features

- 1/3 inch Sony Super HAD CCD
- High Resolution : 550 TV Lines
- Built-in DC Iris Vari-focal Lens(f=4-9mm)
- Day&Night (ICR), 2x Digital Zoom (On/Off)
- Digital Slow Shutter (On/Off)
- SDNR (Super Digital Noise Reduction)
- Auto White Balance
- AGC, BLC, Flickerless (On/Off)
- Min : Day (0.3 Lux),Night(0.001Lux, DSS&ICR)
- Dual Voltage
- 3—Axis Camera Construction
- Dome Size : 100mm
- Audio Function (Option)



### DIMENSIONS

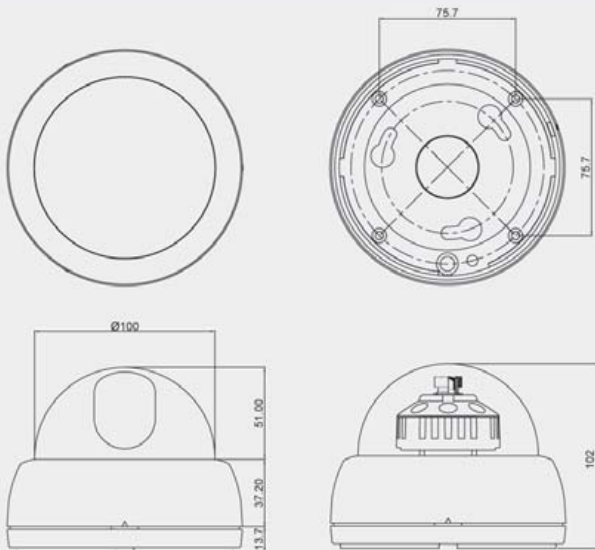

### SPECIFICATIONS

| Model                    | -D2815NVD                                  | -D2815PVD              |
|--------------------------|--|------------------------|
| Signal System            | NTSC                                       | PAL                    |
| Scanning System          | 2:1 Interlace                              |                        |
| Scanning Frequency (H)   | 15.734 kHz                                 | 15.625 kHz             |
| Scanning Frequency (V)   | 59.94 Hz                                   | 50 Hz                  |
| Image Sensor             | 1/3 Inch SONY Super HAD CCD                |                        |
| Total Pixels             | 811 (H) x 508 (V) 410K                     | 795 (H) x 596 (V) 470K |
| Total / Effective Pixels | 768 (H) x 494 (V) 380K                     | 752 (H) x 582 (V) 440K |
| Horizontal Resolution    | 550 TV Lines                               |                        |
| Video Output             | No   |                        |
| S/N Ratio                | More than 50dB(AGC Off)                    |                        |
| Lens                     | Built in DC Iris Vari-focal Lens (f=4~9mm) |                        |
| Digital Zoom Ratio       | 2x (On/Off, DIP Switch)                    |                        |
| Min.Illumination         | Day (0.3Lux), Night(0.001Lux, DSS&ICR)     |                        |
| D&N (ICR)                | On/Off (DIP Switch)                        |                        |
| SDNR                     | Built in                                   |                        |
| DSS                      | On/Off (DIP Switch)                        |                        |
| White Balance            | Auto                                       |                        |
| AGC/BLC/Flickerless      | On/Off (DIP Switch)                        |                        |
| Shutter Speed            | 1/60~1/120,000                             | 1/50~1/120,000         |
| Power Consumption        | Max. 1.8W/150mA                            |                        |
| Supplied Voltage         | Dual Voltage DC 12V and AC 24V             |                        |
| Dimensions(ØxH)          | 100.0 x 102.0 mm                           |                        |
| Weight                   | Approx. 366g                               |                        |